



# ENFORCER

## 60W HEAVY DUTY LED WORK LAMP

The Dura Vision Enforcer 60w LED work lamp offers the latest in high powered LED technology, designed for use on heavy duty mining vehicles. With a compact design, waterproof to IP69 and vibration ratings of 25G RMS the Enforcer provides lighting solutions in the most demanding environments. Electronic Thermal management ensures a minimum of 50'000 working hours is achieved, even when used continuously. Utilising a 5mm stainless steel bracket with 145° of adjustment the Enforcer is one of the most versatile lamps available. The Enforcer is also available as a 24V only option to deter theft of lamps on site.



MINING & HEAVY MACHINERY LIGHTING

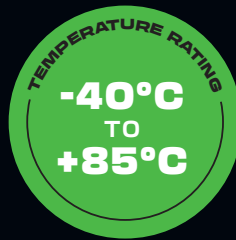

PRODUCT NAME	ENFORCER 60W HEAVY DUTY LED WORK LAMP
MODEL	ENFORCER
WATTAGE	60W
BEAM ANGLE	25°, 40°, 60°, 70x40°, 110°
LIGHT OUTPUT RAW	9,100lm
LIGHT OUTPUT EFFECTIVE	6,480lm
VOLTAGE	9-36V or 24V only
OPERATING TEMP	-40°C to +85°C
IP RATING	IP69
VIBRATION RATING	25GRMS
CONNECTOR TYPE	2 Pin Deutsch
HOUSING	Die-Cast Alloy
LENS	Polycarbonate
BRACKET	5mm Stainless Steel
CURRENT DRAW	2.5A @ 24V
CRI	70CRI
CCT/KELVIN	3000K, 4000K or 5700K
DIMENSIONS	154x148x99mm
NET WEIGHT	2.5kg
EMC RATING	CISPR 25 Class 3
MOUNTING SUITABLE	Upright & Pendant
EXPECTED LIFESPAN	50,000 hours
DIMMING CONTROL	YES (Optional)
WARRANTY	5 Years

Find out more at [dura-vision.com.au](http://dura-vision.com.au) or call 1800 66 55 66



# ENFORCER

60W HEAVY DUTY  
LED WORK LAMP



MINING & HEAVY MACHINERY LIGHTING

## DESIGNED FOR

- ✓ HAUL TRUCKS
- ✓ BULLDOZERS
- ✓ DRILL RIGS
- ✓ GRADERS
- ✓ EXCAVATORS
- ✓ SHOVELS
- ✓ UNDERGROUND DRILL RIGS
- ✓ UNDERGROUND GENERAL LIGHTING
- ✓ EMI SENSITIVE APPLICATIONS
- ✓ UNDERGROUND WHEEL LOADERS

## TECHNICAL DRAWINGS

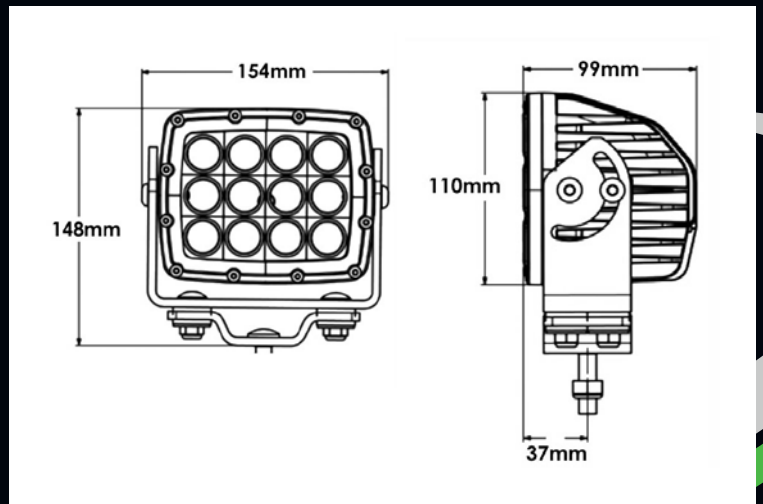

## BEAM PATTERNS

