



INVADER

50W HEAVY DUTY LED WORK LAMP

The Dura Vision Invader 50w LED work lamp offers the latest in high powered LED technology, designed for use on heavy duty mining vehicles. With a compact design, waterproof to IP69 and vibration ratings of 25G RMS the Invader provides lighting solutions in the most demanding environments. Electronic Thermal management ensures a minimum of 50,000 working hours is achieved, even when used continuously. With a slightly smaller footprint than the Enforcer but utilising a similar 5mm stainless steel bracket the Invader is one of the most versatile lamps available. The Invader is also available as a 24V only option.



MINING & HEAVY MACHINERY LIGHTING

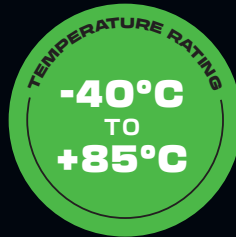

PRODUCT NAME	INVADER 50W HEAVY DUTY LED WORK LAMP
MODEL	INVADER 50
WATTAGE	50W
BEAM ANGLE	25°, 40°, 60°, 70x40°, 110°
LIGHT OUTPUT RAW	6,800lm
LIGHT OUTPUT EFFECTIVE	5,248lm
VOLTAGE	9-36V or 24V only
OPERATING TEMP	-40°C to +85°C
IP RATING	IP69
VIBRATION RATING	25GRMS
CONNECTOR TYPE	2 Pin Deutsch
HOUSING	Die-Cast Alloy
LENS	Polycarbonate
BRACKET	4mm Stainless Steel
CURRENT DRAW	2.1A @ 24V
CRI	70CRI
CCT/KELVIN	3000K, 4000K or 5700K
DIMENSIONS	122x145x91mm
NET WEIGHT	1.8kg
EMC RATING	CISPR 25 Class 3
MOUNTING SUITABLE	Upright & Pendant
EXPECTED LIFESPAN	50,000 hours
DIMMING CONTROL	YES (Optional)
WARRANTY	5 Years

Find out more at dura-vision.com.au or call 1800 66 55 66



INVADER

50W HEAVY DUTY
LED WORK LAMP



MINING & HEAVY MACHINERY LIGHTING

DESIGNED FOR

- ✓ HAUL TRUCKS
- ✓ BULLDOZERS
- ✓ DRILL RIGS
- ✓ GRADERS
- ✓ EXCAVATORS
- ✓ SHOVELS
- ✓ UNDERGROUND DRILL RIGS
- ✓ UNDERGROUND GENERAL LIGHTING
- ✓ EMI SENSITIVE APPLICATIONS
- ✓ UNDERGROUND WHEEL LOADERS

TECHNICAL DRAWINGS

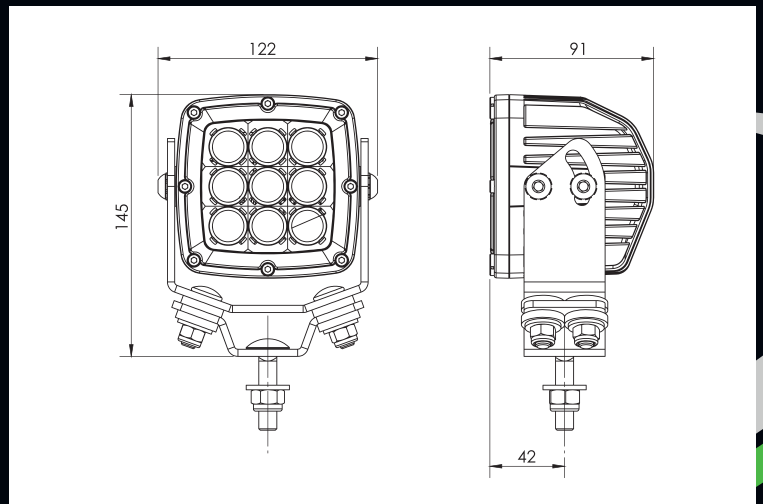

BEAM PATTERNS

