



# ZONE MASTER™

## HEAVY DUTY LED AC FLOOD LIGHT 180W-480W

An ultra rugged, tough and versatile LED flood light that boasts industry leading vibration resistance, rated to 15.8G RMS, designed to handle extreme vibration for the mining and heavy industrial applications. The housing is manufactured from a tough, extruded aluminium with stainless steel lens retaining bezels and basketry makes this waterproof IP68 flood lamp resistant to the most demanding applications. Proudly designed and built in Australia.



MINING & HEAVY MACHINERY LIGHTING

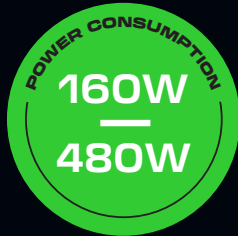

PRODUCT NAME	ZONE MASTER™ HEAVY DUTY LED AC FLOOD LIGHT			
MODEL	180W	240W	320W	480W
PART NUMBER	DVZ-180	DVZ-240	DVZ-320	DVZ-480
POWER CONSUMPTION	180W	240W	320W	480W
LIGHT OUTPUT EFFECTIVE	23,400 lm	31,200 lm	41,620 lm	62,400 lm
LED EFFICACY	130 lm/W			
IP RATING	IP68			
OPERATING TEMP °C	-40°C to +70°C			
NOMINAL VOLTAGE	230V/AC			
VOLTAGE RANGE	90-305V/AC or 127-420V/AC			
POWER FACTOR	>0.95			
FREQUENCY RANGE	47-63Hz			
THERMAL MANAGEMENT	Electronic Active / Continuous			
CRI	70 CRI			
CCT/KELVIN	3000K, 4000K & 5700K			
HOUSING	Extruded Aluminium			
BRACKET	304 Stainless Steel			
LED BIN SELECTION	5 SCDM Ellipses			
VIBRATION RATING	15.8G/RMS			
LINE CURRENT (230V/AC)	0.8A	1.0A	1.4A	2.0A
DRIVER	External or Junction Box			
LENS	3mm Polycarbonate			
CABLE TYPE	3pin Aust Moulded Plug			
CABLE LENGTH	Custom			
EXPECTED LIFESPAN	50,000+ hours			
SURGE PROTECTION	10kV			
NET WEIGHT	7kg	8kg	9kg	12kg
EMC COMPLIANCE	AS/NZS CISPR15			
SAFETY COMPLIANCE	AS/NZS 60598.1			
WARRANTY	5 YEARS			

Find out more at [dura-vision.com.au](http://dura-vision.com.au) or call 1800 66 55 66



# ZONE MASTER™

HEAVY DUTY LED AC FLOOD LIGHT 180W-480W



## DESIGNED FOR

- ✓ DRAGLINES
- ✓ STACKER / RECLAIMERS
- ✓ CRUSHERS
- ✓ LOADING DOCKS
- ✓ PORTS / WHARF
- ✓ SECURITY PERIMETER
- ✓ ROM PADS
- ✓ HIGH MAST FLOOD LIGHTING

## FEATURES

- 3MM DURABLE POLYCARBONATE LENS
- 304 GRADE STAINLESS LENS CLAMPS
- 6 BEAM PATTERN OPTIONS
- 304 GRADE STAINLESS BRACKET
- SELF-CLEANING COOLING FINNS
- ATMOSPHERIC PRESSURE EQUALISING BREATHER
- UV RESISTANT POLYESTER POWDER COATING
- CUSTOMISABLE POWER CONNECTION OPTIONS

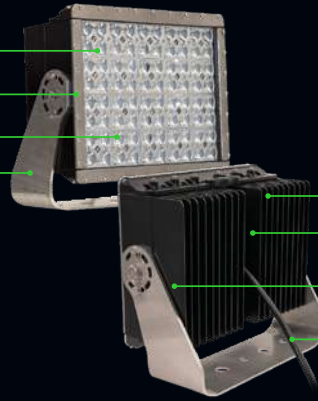

## TECHNICAL DRAWINGS

180W Model

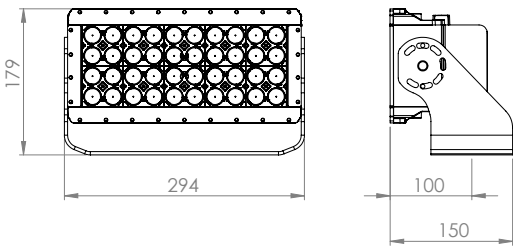

240W Model

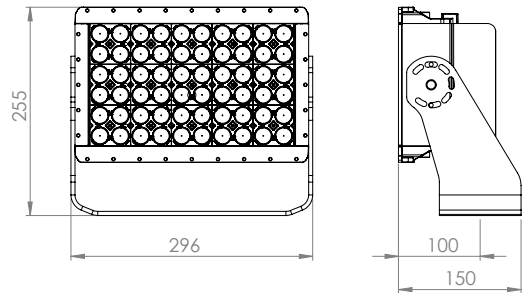

320W Model

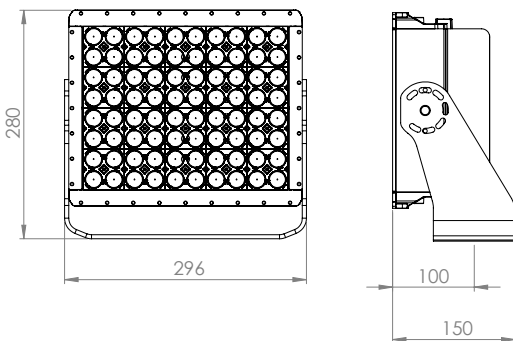

480W Model

